



# STEM

FOR  
YOUTH

ENJOY. SCIENCE TECHNOLOGY ENGINEERING MATHEMATICS.

## **HYDROBOTS**

BUILDING AN UNDERWATER  
ROBOT

OCEAN (MARINE) ENGINEERING

ENGINEERING FOR SECODARY  
SCHOOL STUDENTS

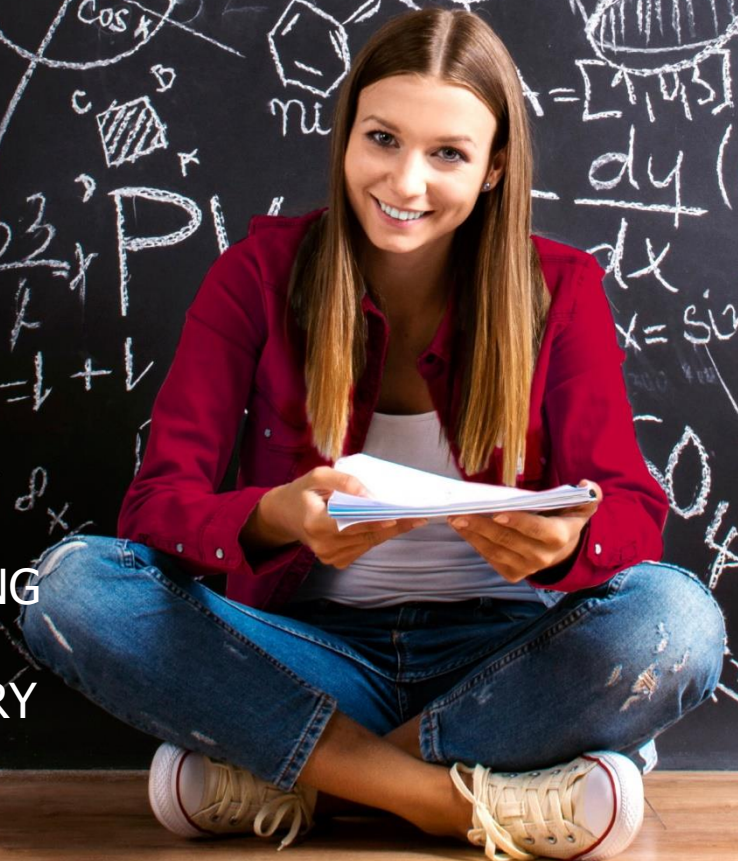

## PROJECT DETAILS

PROJECT ACRONYM	STEM4YOU(th)
PROJECT TITLE	Promotion of STEM education by key scientific challenges and their impact on our life and career perspectives
GRANT AGREEMENT	710577
START DATE	1 May 2016
THEME	SWAFS

## DELIVERABLE DETAILS

WORK PACKAGE NO. AND TITLE	WP5 – CONTENT CREATION, TOOLS AND LEARNING METHODOLOGY DEVELOPMENT
DELIVERABLE NO. and TITLE	<b>D5.1 MULTIDISCIPLINARY COURSE-ENGINEERING SUB-COURSE</b>
NATURE OF DELIVERABLE AS PER DOW	R=Report
DISSEMINATION LEVEL AS PER DOW	PU=Public
VERSION	<b>FINAL</b>
DATE	<b>JULY 2018</b>
AUTHORS	<b>EUGENIDES FOUNDATION</b>



## INDEX

INTRODUCTION .....	4
Activity 0-What is engineering?.....	5
Activity 1-Identifying the problem (what is the engineering problem?) .....	13
Activity 2 – Divide into sub-problems.....	15
Activity 3 – Explore the science .....	16
Activity 4 – Solve sub-problems .....	18
Activity 5 – Combine sub-solutions, test and improve .....	44
Activity 6 – Present Final Solution.....	45
Science Carriers and Your Future .....	46
For Events (tips on setting up and running the challenge in an event setting) .....	47
References.....	48



## INTRODUCTION

This challenge introduces students to the wonders of underwater robotics. Students are invited to build an underwater robot and a propulsion system, to develop a controller, and investigate weight and buoyancy. This challenge teaches basic skills in ship and submarine design and encourages students to explore naval architecture and marine and ocean engineering concepts.

The challenge is based on the SeaPearch program developed by MIT Professors Thomas Consi & Chris Chryssostomides, this activity is inspired by the book "How to Build an Underwater Robot," by Harry Bohm and Vickie Jensen. The program is currently managed by the Association of Unmanned Vehicle Systems International Foundation (AUVSIF).

### Overview of the challenge:

<u>Participant age:</u> 13-18	<u>Number of participants:</u> Groups (3-4 students)	<u>Module length:</u> App. 1,5 hours to 8 hours
<u>Level of knowledge:</u> intermediate, advanced	<u>No. and type of personnel:</u> teacher / external science experts/science museum staff/students	<u>Type of venue:</u> Classroom / outdoors/science museum
<u>Technological needs:</u> internet / computer/ tablet /	<u>Topic as per formal curricula:</u> Floating, mass, volume, density, weight, stability, balanced forces, buoyancy, electric circuits	<u>Estimated cost:</u> low Low (250 € per 5 teams) All the materials are reusable.
<u>Specify learning methodology (D3.1):</u> Engineering Design Process (EDP) Inquiry Based Learning (IBSE) Learning by Doing	<u>Engineering Field:</u> Ocean and Marine	<u>Type of activity:</u> Hands on activity

### **General Objectives: In this hands on activity students will**

- understand the principal role of the materials and their properties in engineering solutions
- get interested in phenomena found in daily life
- develop the ability to predict and verify results
- realize how buoyancy works
- understand how ships float
- realize the difference between natural and man-made objects
- conceive that goals are achieved by collaboration among scientists and engineers
- experience the importance of teamwork as well as individual responsibility as a member of the team
- experience the satisfaction of success
- discover and experience the relationship between theory and practice
- develop a spirit of inquiry
- develop the ability to accomplish a task from start to finish
- develop design skills
- develop the ability to turn designs into reality
- acquire technical skills on using tools properly and safely
- get familiar with the process of finding means to overcome difficulties and problems
- develop the ability to perform experiments and interpret results

### **Activity 0-What is engineering?**

**Duration: 40 minutes (max)**

#### **Objectives: In this activity students will**

- discover the differences between engineering and technology
- associate things, activities or other terms with engineering and technology
- familiarize with different engineering fields
- apply the Engineering Design Process in order to design and construct a paper table

#### **General Context**

This first activity is intended to encourage thinking about what engineering and technology are and to challenge the misconceptions that students may have about the field of engineering or the work of an engineer. This activity aims to disentangle the concepts of engineering and technology and develop the understanding that man-made

objects are designed for a purpose and that technology, in a very broad sense, refers to any object, system or process that has been designed, constructed, modified in order to solve a problem or to meet a certain need. Finally, in this first activity, students are introduced to the process that engineers follow in order to find solutions to the problems they are dealing with. Student teams try to find and construct a solution to a simple problem following the same process as engineers do.

### ❖ Small groups

Teacher arranges students into of 3-4 person groups, preferable mixed gender and aptitude (teams should be kept the same through the entire challenge). Each group is asked to discuss and interpret the concepts of engineering and technology and try to associate things, activities or other terms with these concepts. Students are asked to answer to the following questions and write their answers down:

- i) What is engineering?
- ii) What is the work of an engineer?
- iii) Can you give some every day examples of engineering and technology?
- v) What is the difference between engineering and technology?

After that, the teacher writes student team's answers on the board and initiates a discussion about engineering and technology. He/she seizes the opportunity to introduce the Engineering Design Process (EDP) steps and initiate a quick discussion about each individual step. Finally, the teacher asks student teams to construct a laptop table out of paper, by applying the EDP.

### What is engineering?

The word engineering is of Latin origin; its root is "ingeniere" which means to design or to devise.

Engineering is the application of scientific knowledge (natural sciences, mathematics, economic and social), practical knowledge and empirical evidence in order to solve everyday life problems. More specific, the purpose of engineering is to invent, innovate, design, build, research and improve structures, machines, tools, systems, components, materials, processes and organizations under specific constraints. The field of engineering is very broad and encompasses a great range of more specialized fields [3], [4] such as:

- Aerospace & Aeronautical Engineering
- Agricultural Engineering
- Architectural Engineering
- Biochemical Engineering
- Biological Engineering
- Biomedical Engineering

- Chemical Engineering
- Civil Engineering
- Computer Engineering
- Electrical Engineering
- Environmental Engineering
- Geoscience Engineering
- Industrial Engineering
- Marine Engineering
- Materials Engineering
- Mechanical Engineering
- Metallurgical Engineering
- Ocean Engineering
- Petroleum Engineering

### What is the work of an engineer?

Engineers identify a problem, and come up with a solution – often creating something completely new in the process.

*“Scientists investigate that which already is; engineers create that which has never been.” (Albert Einstein)*

The most famous engineering fields, in more detail [3], [4], are the following:

**Aerospace engineering:** the field of engineering concerned with the development of aircraft and spacecraft. Aerospace engineers design, develop, test, and supervise the construction of aerospace vehicle systems. Such systems are aircrafts, helicopters, space vehicles and launching systems.

**Architectural engineering:** the field of engineering that uses engineering principles to the construction, planning and designing of buildings and other structures. Architectural engineers work in several areas such as: the structural integrity of buildings, the design and analysis of light, heating and ventilation of buildings, energy conservation issues.

**Biological engineering (bio-engineering):** the field that applies concepts and methods of biology, physics, chemistry, mathematics and computer science to solve problems which are related to life sciences. Bioengineers solve problems in biology and medicine by applying principles of physical sciences and engineering while applying biological principles to create devices such as diagnostic equipment, biocompatible materials, medical devices etc. In general, bioengineers try to mimic biological systems in order to create products or modify and control biological systems.

**Chemical engineering:** the field of engineering that applies physics, chemistry, microbiology and biochemistry along with applied mathematics and economy in order to transform, transport and use chemicals, materials and energy. Traditionally chemical engineering was linked to fuel combustion and energy systems, but today’s chemical

engineers work in medicine, biotechnology, microelectronics, advanced materials, energy and nanotechnology.

**Civil engineering:** the engineering field that deals with design, construction and maintenance of constructions such as roads, bridges, dams, buildings, tunnels. Civil engineering is probably the oldest engineering discipline which deals with the built environment. Civil engineers use their knowledge on physics and mathematics to solve society problems.

**Computer engineering:** the discipline that integrates electrical and electronic engineering and computer science in order to design and develop hardware, software, computer systems and other technological devices. Computer engineers embed computers in other machines and systems, build networks to transfer data and develop ways to make computers faster and smaller. Furthermore, computer engineers have expertise in a variety of areas such as software design and coding and are trained to design software and perform and integrate that software with hardware components.

**Electrical engineering:** the field of engineering that deals with the study and application of electricity, electronics and electromagnetism. Electrical engineers conceive, design and develop circuits, devices, algorithms, systems and components that can be used to sense, analyze and communicate data. Electrical engineers work on a variety of projects, such as computers, robots, cell phones, radars, navigation systems and all other kinds of electrical systems.

**Materials engineering:** the field that involves the discovery and design of new materials. Material engineering incorporates physics, chemistry, mathematics and engineering. Materials engineers develop, process and test materials used to create a wide range of products such as computer chips, medical devices, aircraft components etc. Materials engineers are concerned with the structure and properties of materials used in modern technology so they study the properties and structures of metals, ceramics, plastics, nanomaterials and other substances in order to create new materials that meet certain mechanical, electrical or chemical needs.

**Mechanical engineering:** the engineering discipline which applies the principles of engineering, physics and mathematics for designing analyzing manufacturing and maintaining mechanical systems. Mechanical engineers create machines used in manufacturing, mechanical components of electronics, engines and power-generating equipment, vehicles and their components, artificial components for the human body, and many other products.

**Ocean (Marine) engineering:** the branch of engineering study that deals with the design and operations of manmade systems in the ocean and other marine environments. Ocean engineering includes the engineering of boats, ships, oil rigs and any other marine vessel or structure. Ocean engineers apply their engineering (mechanical, electrical, electronic engineering) and scientific knowledge in order to design and develop systems and structures in marine environments. An ideal ocean engineer has to achieve a proper tandem between the marine eco-system and the developed human world.



**Robotics:** the interdisciplinary branch of engineering and science that deals with designing, constructing, programming, controlling, operating and using robots. Robots are used in a wide range of applications which include industrial, military, agricultural, medicine robots etc.

- Industrial robots - take over work that is dirty, dangerous and degrading to the human spirit (e.g. arc welding, grinding, sanding, polishing and buffing, palletizing etc). Typically, these robots are articulated arms particularly created for applications like- material handling, painting, welding and others.
  - Medical robots – robots that are employed in medicine and medicinal institutes such as surgical robots, rehabilitation robots and biorobots.
  - Domestic or household robots – These types of robots are used at home and consist of robotic pool cleaners, robotic sweepers or robotic vacuum cleaners.
  - Military robots – These types of robots are used for offensive or defensive purposes and include bomb discarding robots, ballistic shield robots, inspection robots, attacking drones etc.
  - Space robots - Robotic devices used to aid, augment, or substitute astronauts in order to do difficult or rote tasks such as exploration or repairs in dangerous environments (e.g. space station robotic arms, Mars rovers Spirit and Opportunity).
  - Deep Sea robots – Robots that have long-term presence in the deep ocean and carry equipment to measure various parameters that scientists are interested in (e.g. Benthic Rover).
- Engineering Misconceptions
- Plumber
  - Electrician
  - Carpenter
  - Auto Mechanic
  - PC (Personal Computer) Technician
  - Welder
  - Machinist

### What is technology?

Engineering and technology are intertwined terms in society. In order to disentangle the two terms, one needs to understand what their meaning is. Engineering is both a field of study as well as application of scientific knowledge to create or produce something. On the other hand, technology is the collection of techniques, skills, methods and processes used in the production of goods or services or in the accomplishment of objectives, such as scientific investigation. Technology can be the knowledge of techniques and processes, or it can be embedded in machines, computers, devices, and

factories, which can be operated by individuals without detailed knowledge of the workings of such things.

## Engineering Design Process

The teacher introduces the EDP steps to the students. A short description of the Engineering Design Process follows.

The Engineering Design Process (EDP) is a series of steps that engineers follow when they are trying to solve a problem they are facing and consists of a methodical approach. However, there is no single design process which is universally accepted. In general, each individual design process begins with identifying the problem and its requirements and ends up with a proposed solution. The intermediate steps, however, can vary. It is very important to point out that EDP is not a linear process. Since, engineering problems can have numerous correct answers; the process may require backtracking and iteration. The solution to an engineering problem is usually subject to unexpected complications and changes as it develops. In this project we propose a series of steps which are described below.

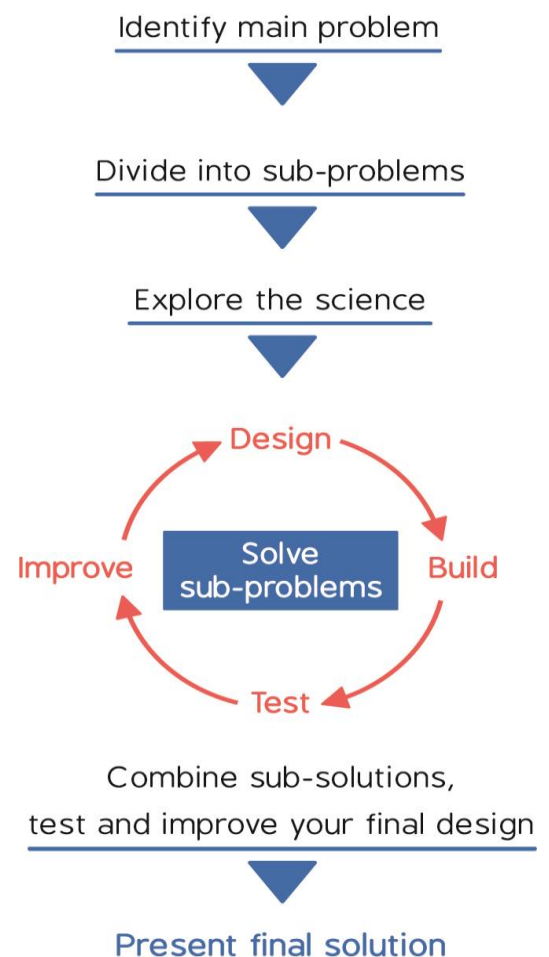

Figure 1: EDP steps

### **1. Identify the problem**

Engineers ask critical questions about the problem and what they want to create, whether this is a space station, a skyscraper, a car or a computer. These questions include:

- *What is the problem?*
- *Define the problem in specific terms. Be as specific as possible.*
- *Which are the available materials?*
- *What do we need to know in terms of scientific principles that underlie the problem?*
- *What are the constraints of the problem? (Budget, time etc.)*
- *Which are the criteria that must be met so that the solution is acceptable?*

## **2. Divide problem into sub-problems**

Usually big problems consist of a series of sub-problems. So, engineers analyze the problem in order to plan their work.

- *Is the solution to the main problem straight forward?*
- *Does the main problem consist of smaller and simpler problems?*
- *Engineers do not attempt to plan the whole thing at once. Large projects have many variables that you do not know and can affect the whole plan.*
- *Engineers set smaller goals. Instead of trying to plan everything from the beginning, they figure out the first obvious step and then move to the next one.*

## **3. Explore the science**

After dividing the main problem to the sub-problems it consists of, engineers investigate the scientific principles that underlie each sub-problem. The fundamental background science is essential for solving sub-problems and designing the optimum solution.

- *What areas of science cover my project?*
- *Which are the scientific principles that underlie each sub-problem?*
- *Research background theory*
- *Perform experiments-tests to understand the theory's applications.*

## **4. Solve sub-problems**

Generate as many solutions as possible by brainstorming and examine the advantages and the disadvantages of each possible solution. Evaluate all the solutions in order to identify the optimum.

- *Design: Design the application of the chosen solution, carefully and with as much detail as possible. Draw a diagram of the solution and make a list of materials you need.*
- *Build: Follow your design and develop your solution of each one of the sub-problems*
- *Test: Test whether the solutions of individual sub-problems are compatible with each other*
- *Improve: Make the necessary corrections and improvements*

## **5. Combine sub-solutions, test and improve**

Combine the different components that will provide you the final, integrated solution to the main problem.

Test and if necessary improve your final design

- *Does it work?*
- *Does it solve the need?*
- *Does the final design meet the criteria set?*
- *Analyze and talk about what works, what doesn't and what could be improved.*
- *Discuss how you can improve your solution*

## 6. Present final solution

Review and evaluate your work and present your final solution in front of an audience.

### Preparatory activity - Strong Paper Table

This activity is designed as a way to introduce students to the EDP in order to have a common understanding of how it works and help teachers who are not familiar with engineering and technology in their classrooms.

*Can you build a newspaper table that won't collapse under the weight of a laptop?*

Student teams are asked to follow the design process to build a sturdy and steady laptop table out of paper. Find a way to make paper support weight and prevent the legs of the table from buckling (see Fig. 2 for possible solutions).

#### Criteria

- The table must withstand a weight of 2-3 kg.
- The table must be sturdy and stable.
- The table's surface must be inclined to make the use of keyboard easier.
- The table's surface must be ventilated, to prevent laptop from overheating.

#### Constraints

- The available materials are 5 newspapers and 50 A4 sheets of paper.
- The available tools are duct tape and a pair of scissors.
- The available time is 30 minutes

*-Tip: From the criteria the main problem can be divided into sub-problems*

- *Stability and durability of the table*
- *Inclination*
- *Ventilation*



Figure 2: Possible Solutions

## Activity 1-Identifying the problem (what is the engineering problem?)

**Duration:** 20 minutes

**Objectives:** In this activity students will

- familiarize with materials and tools such as pliers, screw drivers, screws etc.
- reflect the role of materials in designing a solution to their problem

### **General Context**

In this activity the teacher sets the engineering problem that students have to face. Student teams ask questions concerning the problem they are facing and discuss with their teacher the criteria that their solution must meet as well as the constraints they have. Afterwards, each team prepares a problem statement i.e. a brief description of the issues that need to be addressed by a problem solving team and should be presented to them (or created by them) before they try to solve a problem. Finally, student teams discuss with their teacher about materials that could be appropriate for their challenge. Different types of materials and tools are provided to student teams and the teams explore and become familiar with the materials.

## ❖ Working in groups

The teacher briefly introduces the Engineering Challenge: “Each team has to build a remotely operated underwater vehicle”.

The teacher states that engineers who face and deal with problems such as the one under study are called *Ocean (Marine) Engineers*. (Description of this field is provided in Activity 0).

The teams are encouraged to ask questions concerning the problem:

- What is the problem or need?
- Which are the criteria that their solution must meet?
- What are the constraints of the problem?
- Which are the available materials, tools, resources and technologies?
- Which are the scientific principles behind the problem?
- Which every-day materials that can be found at home or at a local hardware shop that can be useful for solving the problem?

Each team is asked to prepare a problem statement. A good problem statement should answer these questions:

1. What is the problem? This should explain why the team is needed.
2. Who has the problem or who is the client/customer? This should explain who needs the solution and who will decide the problem has been solved.
3. What form can the resolution be? What is the scope and limitations (in time, money, resources, technologies) that can be used to solve the problem?

*The problem must be specific enough to allow each team to design a solution.*

The teacher then provides student teams with different materials (the teacher can provide student teams with extra materials that are not appropriate for the final design) and tools. Student teams are given some time to become familiar with the materials and tools and then discuss with their teacher possible uses of them. The teacher should encourage student teams to ask questions concerning the criteria that their solution must meet and the constraints of the problem.

### Constraints

- Available materials
- Available tools
- Available time
- The vehicle’s size
- Cost
- Security Issues

### Criteria

- The vehicle must be able to navigate underwater (up-down-right-left)
- The vehicle must be remotely controlled
- Mechanical-parts must be waterproof

## Activity 2 – Divide into sub-problems

**Duration:** 15 minutes

**Objectives:** In this activity students will

- break the main problem to simpler problems
- organize their goals
- schedule their work and set time limits
- draft a plan how they will work

### **General Context**

In this activity, student teams move to the second step of the Engineering Design Process which is to divide the main problem into sub-problems. Student teams try to analyze and divide the bigger problem to smaller and easier to handle sub-problems. They also try to match materials to each sub-problem. Student teams write down and justify their thoughts. The teacher reminds the criteria and constraints that should be met.

### **❖ Working and discussion with all teams**

Teacher initiates a discussion about the fact that an easy way to deal with a large project is to break it into smaller tasks which are more manageable and easier to face. However, he/she should point out that the task of getting a large goal divided into smaller and achievable ones is not very easy and in fact it can be something quite hard to do. The teacher can propose some simple guidelines that if followed can make the process of breaking the problem, easier. After that student teams should be prompted to propose possible sub-problems.

### **Guidelines**

- Do not attempt to plan the whole thing at once. Large projects have many variables that you do not know and can affect the whole plan.
- Set smaller goals. Instead of trying to plan everything from the beginning, figure out the first obvious step and then move to the next one.
- Do not hesitate to re-divide. If you are procrastinating on any of the smaller task, do not hesitate to analyze to simpler ones.
- Set time limits. Usually, when engineers deal with a complex problem, apart from the problem itself they have to face time limitations. So in order to be effective manage your time as good as possible.

### **Safety**

- Each student must wear safety goggles
- Provide each student with enough space for soldering
- Ask student to put soldering irons in holders when they are not using them.

- Instruct students to use a vise when soldering and drilling. Always use goggles while soldering and drilling.

The main problem can be divided into three sub-problems:

1. Sub-problem 1: The Vehicle's Frame
2. Sub-problem 2: The Propulsion System
3. Sub-problem 3: The Remote Control

## Activity 3 – Explore the science

**Duration:** 50 minutes

**Objectives:** In this activity students will

- perform experiments concerning the physical principles behind floating and sinking
- organize and classify their observations
- predict and verify results
- familiarize with the third step of the Engineering Design Process

### **General Context**

The purpose of this activity is to get students in touch with the **process of exploring the science behind the problem and/or sub-problems**. Student teams start to think about the necessary knowledge they need in order to solve the engineering problem. Student teams are encouraged to pose investigative questions which if answered will help them in the process of dealing with the problem. They perform specific experiments that will guide them answer their questions about the science that underlies the problem. Student teams are guided through the process of acquiring the necessary scientific knowledge they need for solving the problem. As this activity progresses, students discuss with the teacher the science that underlies the problem. In addition, students organize their observations/ answers.

### **❖ Working in groups**

The teacher's goal is to introduce students to the third step (Explore the science) of the EDP and to motivate them start thinking about the scientific knowledge they need to know and to start brainstorming on how this knowledge can be applied by imagining possible solutions to the engineering problem. Teacher should focus on the scientific principles that underlie the challenge. Student teams are asked to brainstorm and pose questions concerning the science behind underwater vehicles.

The key questions which are important to investigate and are the focus of this activity are:

- What prevents an object that floats from moving towards the bottom of the sea?



- Does water exert force on any objects we immerse in it? If so, on what does this force depend?
- Is there a relationship between the mass of an object and its volume so that the object can float?

### The science behind Hydrobot (Experiments)

Student teams are asked to perform (or discuss) the following experiments, which will guide them through the basic physical laws and principles they need to know in order to find a solution to the problem they are facing. **Note:** *The following experiments are recommended or optional. Teacher may skip some of them or perform others of his/her choice. The challenge takes into account the realities of a teacher's life such as limitations of time, and equipment/materials, the amount of flexibility they have within their curricula, and other particular constraints imposed by their curricula.*

1. Have student teams use a dynamometer to weigh four different fishing weights outside and within water. Before performing the measurements, have them predict whether the indication of the dynamometer will be the same, smaller or larger. After experimenting, have them try to explain the difference indications of the dynamometer.

*The indication of the dynamometer will be smaller when the objects are immersed in the water. This can happen only if an upward force is exerted on the object from the water (buoyant force). In both experiments we have a downward pull exerted on the dynamometer's spring by the object's gravity (weight). However, in the second experiment, we also have an upward push exerted from the water to the object (buoyancy).*

2. Have student teams inflate a balloon and try to push it under water. Have them predict what will happen if they inflate the balloon until it gets twice the initial volume. Have them perform the test and try to explain it.

*As one pushes the inflated balloon in the water, he/she can feel the upthrust from the buoyant force. The more inflated the balloon, the harder you need to push in order to immerse it. This reveals the fact that the upward force which the water exerts becomes greater. We can thus conclude that the buoyant force depends directly on the amount of an objects' immersed volume. So, the greater the objects' immersed volume, the greater the buoyant force becomes.*

3. Provide each team with a plastic watertight container and about 10 small fishing weights. Have them fill the container with weights and predict what will happen if they place it in water. After testing, ask them to remove gradually weights and each time have them predict and test whether the container will sink or float. Have them write down their predictions, observations and their opinion about which variable of the problem they gradually changed.

*When the container is full of fishing weights it will sink because the container's weight is greater than the buoyant force, which is exerted by the water on the container. As fishing weights are removed from the container, the container's weight is reduced, while the volume of the container remains constant. There will be a point (when enough fishing*

*weights are removed) when the buoyant force will equal the container's weight and that is when the container will float. However, one may think that the buoyant force will need to be greater than the container's weight in order for the container to float. In this situation, the teacher should ask: If buoyancy (upward force) is greater than the object's weight (downward force) then why isn't the object ejected out of the water?*

4. Provide each team with the following materials: balloon, 4-5 fishing weights, baking soda, and paper napkin. Ask them to put the fishing weights inside the balloon and add some water in the balloon. Have them place a tea spoon of baking soda on the napkin, fold carefully, place it in the balloon and seal tightly the balloons nozzle. Ask them to place the balloon in the water and observe what will happen. Ask them to identify the parameter that has changed and to explain the outcome of the experiment.

*The stuffed balloon will initially sink because its weight is greater than the buoyant force exerted on the balloon by the water. As the napkin gets wet, a chemical interaction takes place between water and baking powder. This interaction produces gas which inflates the balloon. As a consequence, the balloon begins to inflate (increasing its volume) and the buoyant force gradually getting bigger and bigger. When the buoyant force becomes greater than the balloon's weight, the balloon begins to move towards the water's surface. When the balloon reaches the surface, the amount of the balloon's immersed volume becomes smaller and so, therefore, does the buoyant force. At some point, the buoyant force becomes equal to balloon's weight and that is when the balloon floats (weight = buoyancy and hence floating occurs).*

## Activity 4 – Solve sub-problems

**Duration:** 4.5-5 hours

**Objectives:** In this activity students will

- solve each sub-problem based on their plans
- use tools properly and safely

### **General Context**

In this activity students are introduced to the core of the Engineering Design Process and apply the corresponding steps of EDP to face their challenge. After the completion of activities 1, 2 and 3 they move to the construction process. In order to face and solve each sub-problem they follow the circle: design-build-test-improve. As a part of the whole EDP process students need to recall the scientific knowledge they gained in Activity 3.

### **❖ Working in groups**

The teacher summarizes the conclusions of Activities 1, 2 and 3. As student teams have already defined the individual sub-problems, the teacher encourages and guides

student teams to gradually solve each one of the sub-problems that the main challenge has been divided into. Student teams are also asked to classify the available materials according to the sub-problem they believe that are suitable for. The teacher encourages the teams to draft a plan of their work and a simple design illustrating the different components of the final design, i.e. the vehicle frame, the propulsion system etc. Finally, student teams are asked to move on the construction part. **Note:** *This activity must be performed taking into consideration the construction instructions (see related part below).*

The teacher should take into account the following:

➤ Sub-problem 1: The Vehicle Frame

The following are required for this sub-problem:

Tools	Materials
<ul style="list-style-type: none"> <li><input type="checkbox"/> Measuring tape</li> <li><input type="checkbox"/> Marker pen</li> <li><input type="checkbox"/> PVC pipe cutter</li> <li><input type="checkbox"/> screwdriver</li> <li><input type="checkbox"/> Electric drill</li> <li><input type="checkbox"/> 6mm Drill bit</li> <li><input type="checkbox"/> 2mm Drill bit</li> <li><input type="checkbox"/> Clamp</li> </ul>	<ul style="list-style-type: none"> <li><input type="checkbox"/> 1 PVC pipe 30.8 cm long</li> <li><input type="checkbox"/> 3 PVC pipes 33.2 cm long</li> <li><input type="checkbox"/> 10 PVC elbows of 22 mm diameter</li> <li><input type="checkbox"/> 4 white PVC "T", of 22 mm diameter</li> <li><input type="checkbox"/> 1 pvc electrical pipe 40 cm long and 1.0 cmdiameter</li> <li><input type="checkbox"/> 2 buoyancy float tubes</li> <li><input type="checkbox"/> 3 metal motor mounts</li> <li><input type="checkbox"/> 6 screws number 6, 1/2 inch</li> <li><input type="checkbox"/> 6 washers number 6</li> <li><input type="checkbox"/> Plastic net</li> <li><input type="checkbox"/> Zip ties</li> </ul>
<p><b>Time:</b> This part requires about 1.5 hours to complete:</p> <ul style="list-style-type: none"> <li>✓ 1 hour to cut the pipes and drill the holes (teacher can cut the pipes before providing them to student teams in order to save time).</li> <li>✓ 1/2 hour to assemble the frame, mount the net and the metal motor bases.</li> </ul>	



Figure 3

## Step 1| Cutting the parts of the frame



Figure 4

### The 30.8 cm pipe

1. Cut a piece of 8 cm length. The remaining part shall be 22.8cm long.
2. Take the 8cm piece and cut it in 4 equal pieces of 2 cm each. These 4 pieces are used to connect the pipes of the float valves.
3. Take the remaining pipe of 22.8 cm and cut it in half, so that you get 2 equal pieces of about 11.4 cm each. Use these two pieces for the frame of the robot, as can be seen in the construction instructions.

### The 33.2 cm pipes

Cut all three 33.2cm pipes in half, so that you get 6 pipes of 16.6cm each.

1. Take 4 pipes of 16.6 cm. Cut each pipe at about 12.8 cm, so that each time a part of 3.8 cm will be left. After cutting, you must have 4 pipes of 12.8 cm and 4 smaller pipes of 3.8 cm each. Use these pipes to construct the frame of the robot.
2. Get the remaining 2 pipes of 16.6 cm. Cut them at 10.2 cm, so that a part of about 6.4 will be left. After cutting, you must have 2 pipes of 10.2 cm and 2 pipes of 6.4cm. Use these pipes to construct the frame of the robot, as described in the instructions.

## Step 2 | Create drain holes in vehicle frame



Figure 5. Drain hole drilled in a PVC elbow

Tools	Materials
<ul style="list-style-type: none"> <li><input type="checkbox"/> Electric drill</li> <li><input type="checkbox"/> 6mm Drill bit</li> <li><input type="checkbox"/> Clamp</li> </ul>	<ul style="list-style-type: none"> <li><input type="checkbox"/> 10 PVC corners of 22 mm diameter</li> </ul>

1. Securely place a PVC elbow in the vise or clamp.
2. Insert the 6mm drill bit into the drill and drill one hole in the outer corner of the pvc elbow.
3. Repeat for all 10 corners.

### Step 3 | Assembling the frame



Figure 6

Materials
<ul style="list-style-type: none"> <li><input type="checkbox"/> Cut pieces of PVC pipe from step 1</li> <li><input type="checkbox"/> The 10 elbows with holes</li> <li><input type="checkbox"/> 4 white PVC "T", of 22mm diameter</li> </ul>

Assemble the frame using all the pieces, as shown in the figure:



Figure 7

## Step 4 | Assembling the buoyancy float tubes and tightening the frame



Figure 8

Tools	Materials
<ul style="list-style-type: none"><li>□ PVC pipe cutter</li></ul>	<ul style="list-style-type: none"><li>□ The assembled frame</li><li>□ 1 pvc electrical pipe 40 cm long and 1.0 cm diameter</li><li>□ The 4 PVC pieces of 2cm each, which were cut at Step 1</li></ul>

1. Cut the pvc electrical pipe in two equal pieces (2 x 19cm).
2. Insert one of the 2 cm PVC pipe pieces into the open end of each of the four PVC elbows.
3. Insert the pvc electrical pipe through the floats, so that the pipe passes from the center of each piece.
4. Push all the parts of the frame together, so that the pipes cannot be disconnected from the frame.



Figure 9

## Step 5 | Connecting the metal bases, which hold the motors, on the frame



Figure 10

Tools	Materials
<input type="checkbox"/> Marker pen <input type="checkbox"/> Phillips screwdriver <input type="checkbox"/> Electric drill <input type="checkbox"/> 2mm Drill bit	<input type="checkbox"/> The assembled frame <input type="checkbox"/> 3 metal motor mounts <input type="checkbox"/> 6 screws number 6, 1/2 inch <input type="checkbox"/> 6 washers number 6

1. Screw the metal mounts on the frame as indicated in Fig. 10. **Attention!** It is important to screw the metal mounts in a straight line along the pipe and in the centre of the distance between the joints. Do not try to screw the mounts on the correct angle on the pipes because pipes can rotate so the angle can be easily adjusted any time..
2. Using the marker pen, mark, through the holes of the metal mounts the exact location on the frame.
3. Use the 2mm drill bit, in order to drill the holes on the pipe.
4. Place washers over the holes of the metal mounts. Pass a screw through the washer and the hole of the metal mount. Screw the mount on the PVC pipe.
5. Do not tighten the screws very much to the end, because at a next step they will be removed, to mount the motors.

### Step 6 | Mounting the plastic net in the base of the frame

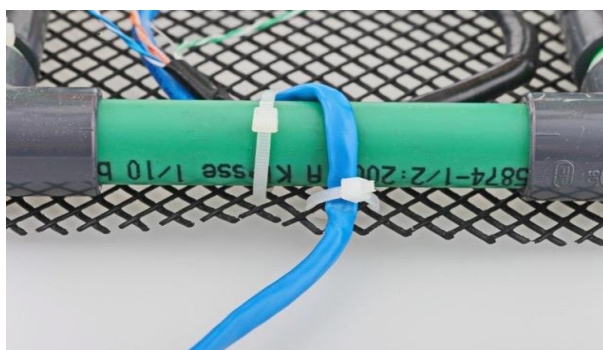

Figure 11

Tools	Materials
<input type="checkbox"/> Cutter or scissors	<input type="checkbox"/> Plastic net <input type="checkbox"/> Plastic zip ties <input type="checkbox"/> The frame

1. Place the net under the frame. Use the scissors to cut the net a little bigger than the base of the frame, as shown in the figure.
2. Mount the net to the frame, using 6-8 plastic zip ties. Tighten the plastic zip ties very well on the frame and cut the pieces that stick out.



Figure 12

➤ Sub-problem 2: The Propulsion System

The following are required for this sub-problem:

Tools	Materials
<input type="checkbox"/> Thinner (tool cleaner and degreaser) <input type="checkbox"/> Measuring tape <input type="checkbox"/> Marker pen <input type="checkbox"/> Pliers <input type="checkbox"/> Screwdriver <input type="checkbox"/> Electric Drill <input type="checkbox"/> Scissors <input type="checkbox"/> Soldering iron <input type="checkbox"/> 2mm Drill bit <input type="checkbox"/> Electric kettle or electric hot plate and Greek coffee pot <input type="checkbox"/> 2 alligator clips	<input type="checkbox"/> Epoxy resin (glue) <input type="checkbox"/> Tether cable 10 m <input type="checkbox"/> 3 plastic containers with their lids (film cans) <input type="checkbox"/> 3 12 Volt DC motors <input type="checkbox"/> 3 plastic propellers <input type="checkbox"/> 3 metal shafts for the propellers <input type="checkbox"/> 6 small nuts for screws (#4-40) <input type="checkbox"/> Epoxy glue and glue stirring stick <input type="checkbox"/> Insulation tape <input type="checkbox"/> Black, butyl, soft rubber <input type="checkbox"/> Red cable <input type="checkbox"/> 12 V Battery
<p><b>Time:</b> This unit takes about 3 hours to be completed:</p> <ul style="list-style-type: none"> <li>✓ 1/2 hour to solder the cables to the motors.</li> <li>✓ 1/2 hour to make the motors waterproof.</li> <li>✓ 1/2 hour to prepare the propellers and to mount the motors to the frame.</li> </ul>	

**Step 1 | Testing the motors and determining polarity**

Tools	Materials



<input type="checkbox"/> Marker pens (red, black) <input type="checkbox"/> 2 alligator clips	<input type="checkbox"/> Motors <input type="checkbox"/> 12 V Battery <input type="checkbox"/> 2 cables, red and black
---	--

1. Strip the cable ends (black and red) by 1 cm and connect them with the alligator clips.
2. **Attention!** Check to see which one is the positive and which one is the negative terminal of the motor and mark them with a marker pen. Red for the positive one (+) and black for the negative one (-). The positive terminal is usually indicated by a red mark near the terminal.
3. Connect one end of the black cable to the negative terminal of the motor and one end of the red cable to the positive terminal of the motor.
4. Connect the motors to the 12 V battery and check their operation. The motors should spin counter-clockwise, if the correct polarity has been selected. If a mistake has been made in polarity, the motor will spin clockwise, and, therefore, the polarity should be changed.
5. **Attention!** Once the positive and the negative terminal of the motor are found, paint them red and black respectively. It is important that the terminals of the motor are painted, in order to avoid any subsequent confusion.

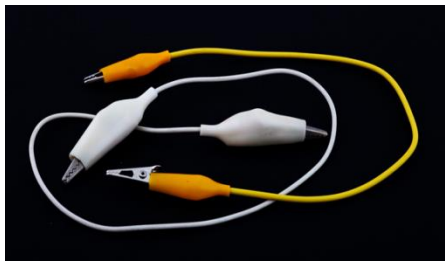

Figure 13

## Step 2 | Protection of the motors from wax

Tools	Materials
<input type="checkbox"/> Scissors	<input type="checkbox"/> 3 12 Volt DC Motors <input type="checkbox"/> Black insulation tape

1. Make sure that the positive terminal of each motor is coloured red (from the previous step), so that they can be easily identified, after the motors have been covered with insulation tape.
2. Wrap the motors with insulation tape, in order to protect them from wax. Cover the terminals of the motor, as well, and press the tape a little, so that it is pierced and the terminals appear (see Fig 14). Do not cover the motor shaft with insulation tape, because its smooth rotation will be hindered this way.
3. Make sure that the motors are fully covered with insulation tape (mainly the holes that the motors contain- see Figs 14-17).



Figure 14



Figure 15



Figure 16



Figure 17

### Step 3 | Drilling holes on the plastic cylinder containers

#### Materials

- 3 plastic containers with their lids (film cans)
- 3 12 Volt DC motors
- 1 cable pair (red-black)

1. Using the 2mm drill bit, drill a hole on the plastic lid of each container. The cables will pass through these holes.
2. Drill a hole exactly in the center, at the bottom of each plastic container. The motor shaft will pass through this hole, therefore be very careful during drilling the holes, so that the shaft fits exactly.
3. Put the motor in the container, so that the motor shaft passes through the hole at the bottom of the container. Connect the motor to the battery, to check if the shaft rotates freely. Repeat for the other two containers as well. **Attention!** The motor shaft should turn freely, with no resistance from the walls.

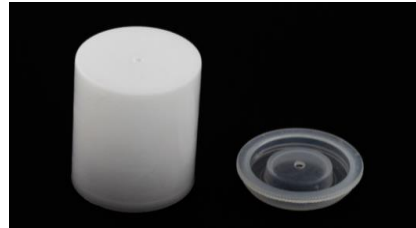

Figure 18

#### Step 4 | Soldering the remote control cable to the motors

Tools	Materials
<input type="checkbox"/> 2mm Drill bit <input type="checkbox"/> Electric drill	<input type="checkbox"/> Blue remote control cable 10m <input type="checkbox"/> 3 plastic containers with their lids (containers and lids bored in the center) <input type="checkbox"/> 3 motors covered with insulation tape

1. Take the tether cable and remove about 38cm of the outer sheath, being careful not to cut the thinner wires inside it.
2. After removing the outer sheath, you will find 4 twisted pairs of wires. 3 out of these 4 pairs will be needed. For this reason, with the scissors or the cutter, cut the pair with the brown wire. **Attention!** Do not throw away the cut wires, as they will be needed later.
3. Separate the 6 remaining wires in 3 pairs (positive/negative) as shown in the Fig. 19 and the following tables.

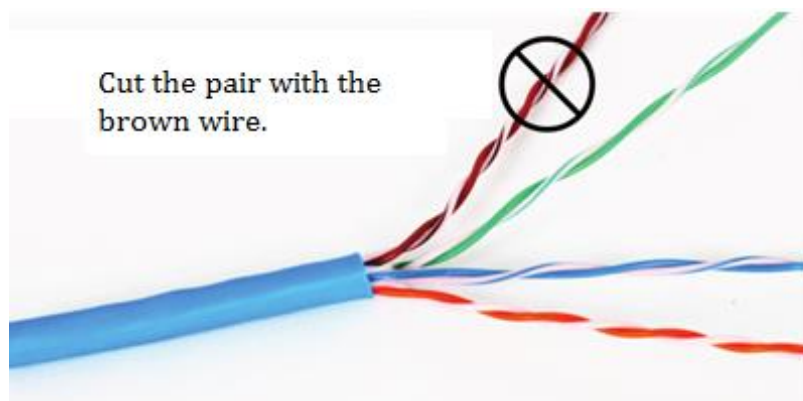

Figure 19.

Positive (+)	Negative (-)	Motor
Green	White	Right
Blue	White	Left
Orange	White	Vertical
Brown	White	Not used

Or

Positive (+)	Negative (-)	Motor
Green	Black	Right
Blue	White	Left
Orange	Yellow	Vertical (up-down)

4. Thread about 10 cm of twisted pair through the hole in each film cap, and tie a knot INSIDE the cap for strain relief (see Fig. 20)

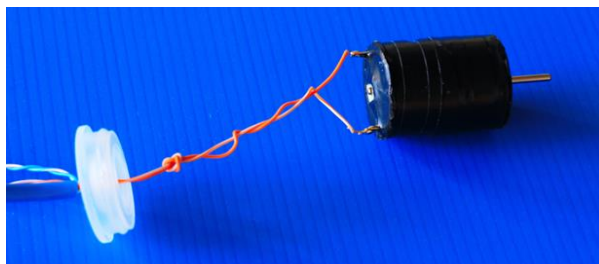

Figure 20

5. Using the soldering iron, solder the cables to the correct terminals of the motors. Make sure that each one out of the three positive cables (green, blue, orange) is connected to the positive terminal of each motor. The positive terminals have been marked with red color at a previous step. Continue, connecting the cables (black, white, yellow) to the negative terminals of the motors.

- Attention!** Make sure that all the solderings are correct and stable, before moving to the next step, of insulating the motors. Try to remove the cables from the terminals of the motors, to make sure they do not come off.

### Step 5 | Sealing the motors with wax

Tools	Materials
<input type="checkbox"/> Electric kettle with melted wax <input type="checkbox"/> Wooden base for the containers <input type="checkbox"/> Needle-nose pliers <input type="checkbox"/> Scissors	<input type="checkbox"/> Insulation tape <input type="checkbox"/> 3 plastic containers with their lids <input type="checkbox"/> 3 motors covered with insulation tape <input type="checkbox"/> Wax

Before starting step 5, a base must be constructed, on which the containers with the motors will lean, after being filled with wax. A simple construction must be made, a base out of wood or cardboard, such as the one shown in the figure.



Figure 21

- Cut a small piece of insulation tape, to cover the hole at the bottom of each plastic container. The tape must be placed lightly, so that, on the one hand, it keeps the wax inside the container, without being poured out, but, on the other hand, the tape should be able to be removed from the motor shaft, when the shaft passes through the hole.



Figure 22

2. Melt the wax either in the Greek coffee pot or in the electric kettle as follows:

**Attention!** Boil the water with the electric kettle and pour it in a tub. Put the wax in a container and dip it into the tub with the boiling water until the wax melts. Alternatively, put the wax in the Greek coffee pot and heat it on an electric hot plate until it melts.



Figure 23

3. Pour melted wax in the cylindrical containers, into which the motors will be put. The melted wax must reach a height of about 7mm in each container.



Figure 24

4. Quickly but carefully, place one of the motors in the plastic container with wax. Push the motor gently, so that its shaft comes out of the hole at the bottom of the

container. The melted wax will cover the sides of the motor, but it will not cover it completely.



Figure 25

5. When all three plastic containers contain a motor each, fill them up with melted wax. Pour melted wax in the container, up to about one centimeter from the top.

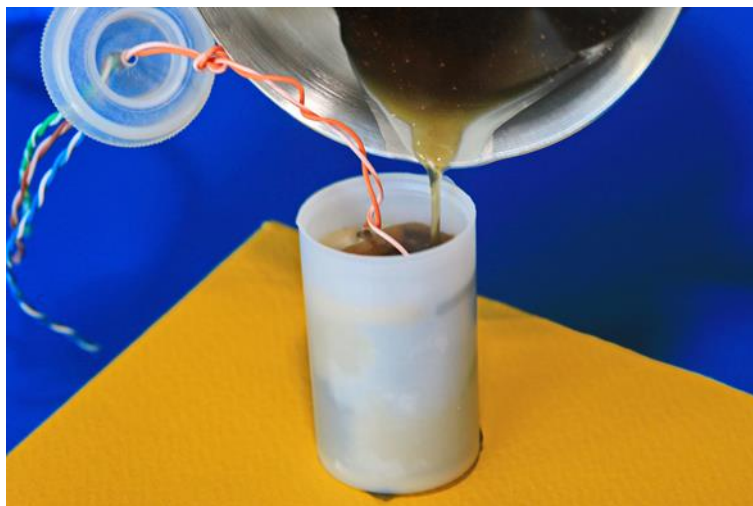

Figure 26

6. Hold the container with your hands and check if there are any bubbles in the wax. Remove these bubbles, by pressing the container all around with your hands. Then put the container on the base for the wax to cool and continue with the other two containers.
7. Once the wax is cooled, fill up the container with the remaining melted wax. Be careful, so that the cables that have passed through the container lid fit in the container when it is closed with the lid. Pour melted wax until each container is full and its surface creates a positive crescent.



Figure 27

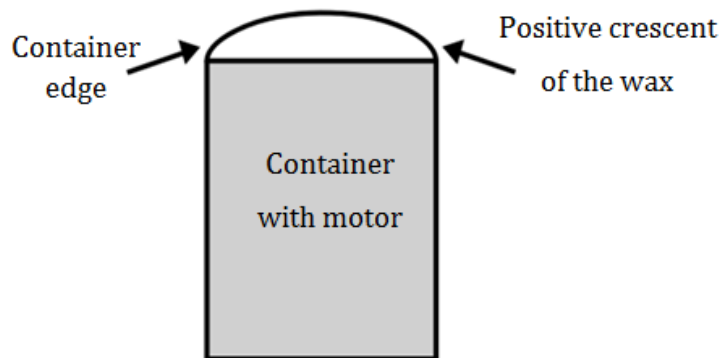

Figure 28

8. Quickly but carefully, place the lid on the container with the melted wax and the motor. Push, so that it closes well and no air gets into the container. Repeat exactly the same procedure for the other two containers as well.



Figure 29

## Step 6 | Mounting the propeller to the motor



Tools	Materials
<ul style="list-style-type: none"> <li><input type="checkbox"/> Thinner</li> <li><input type="checkbox"/> Pliers</li> </ul>	<ul style="list-style-type: none"> <li><input type="checkbox"/> 3 plastic propellers</li> <li><input type="checkbox"/> 3 metal shafts for the propellers</li> <li><input type="checkbox"/> Stirring stick</li> <li><input type="checkbox"/> Epoxy resin (glue)</li> <li><input type="checkbox"/> 6 small nuts for screws (#4-40)</li> <li><input type="checkbox"/> 3 sealed motors in their containers</li> </ul>

1. Wipe the wax from the shaft of each motor. The shaft must be clean and dry, because epoxy glue will be applied on it. Use paper towel and thinner to clean the shafts.
2. Screw a nut tightly on the metal shaft of each propeller.
3. Each propeller has two holes. Put a nut in each one of these holes.
4. On a piece of cardboard, empty the two separate materials of the epoxy glue and mix them well with a stick (see Fig. 30).



Figure 30

5. Apply glue on the propeller shaft, as well as on the nut you screwed on the shaft. Screw one propeller to each shaft (the shaft will pass through the wedged nuts of the propeller) and add one last nut to the shaft end over the propeller. Tighten the nut and add one drop of epoxy glue to it (see Figs 31, 32.).

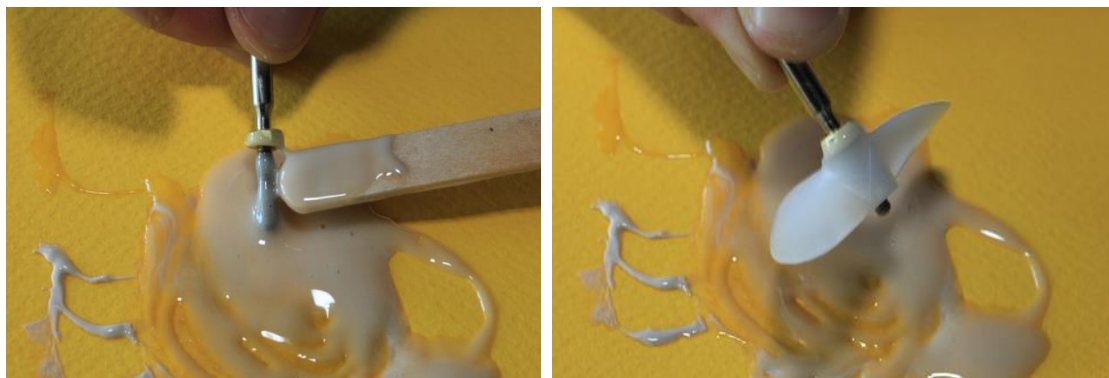

Figure 31



Figure 32

6. There must be 2 nuts, in total, on each propeller shaft: one in front of and one behind the propeller.

7. Add one drop of epoxy glue to the hollow part of the propeller shaft. Push this hollow part over the motor shaft, pushing it to the end. Complete for all the motors and let them dry (see Fig. 33).

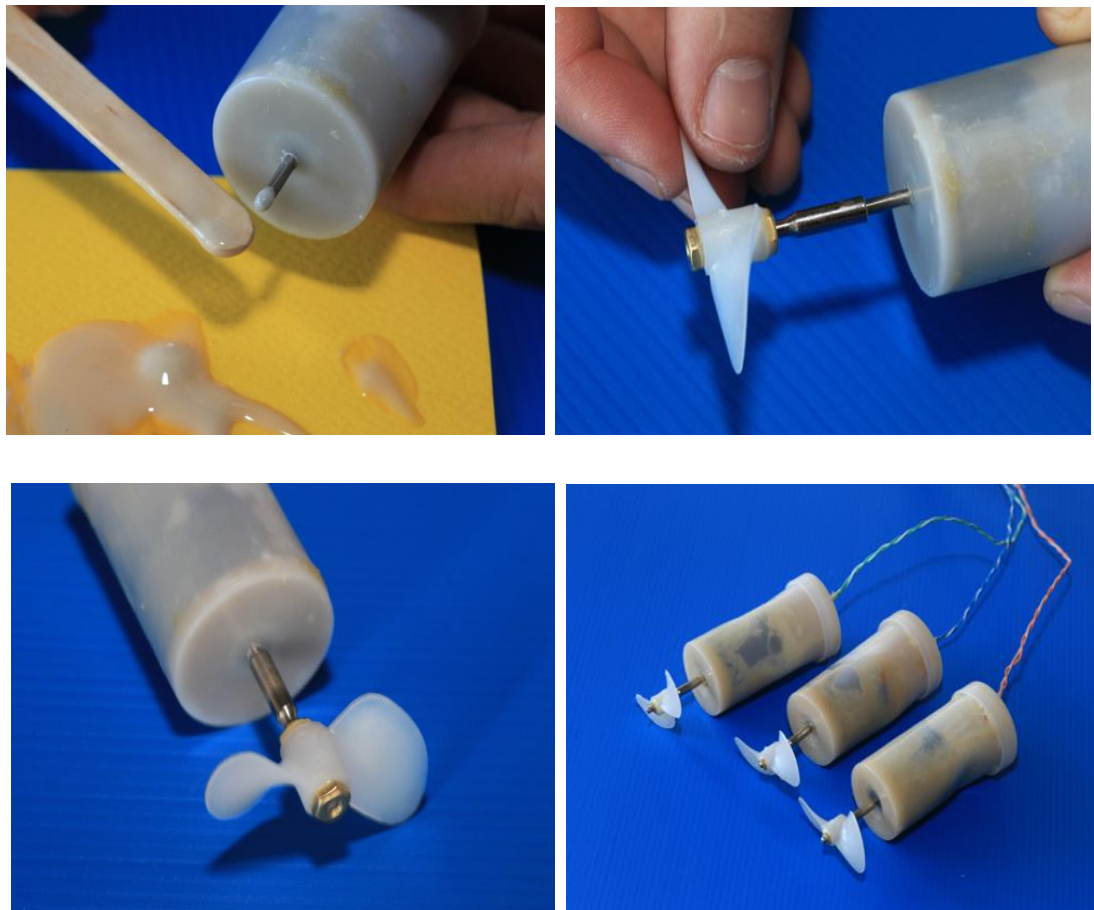

Figure 33

## Step 7 | Mounting the motors to the frame

Tools	Materials
<input type="checkbox"/> Screwdriver	<input type="checkbox"/> 3 motors <input type="checkbox"/> Frame

1. Use the screwdriver to remove the metal mounts from the frame.
2. Place a motor (which now is in a container with wax) inside each motor mount. The motor mount should go over the back end of the motor. It should not be over the back of the can where there is only wax, or over the center of the motor, where it might squeeze the motor casing, but over the back end of the motor, which will best resist the pressure of the motor mount.
3. The metal mounts with the motors are now re-mounted to the frame. The positions are defined by the table that follows.

Positive (+)	Negative (-)	Motor
Green	Black	Right
Blue	White	Left
Orange	Yellow	Vertical (up-down)

**Note:** The indications “right” and “left” for the motors are as you see the frame from its rear side.

4. The containers containing the motors will be slightly compressed while screwing the metal mounts on the frame, but this is expected.
5. Apparently, by rotating the plastic pipes (of the frame), on which the motors have been screwed, you can give the motors the desired tilt.

### Step 8 | Waterproofing the remote control cable

Tools	Materials
<input type="checkbox"/> Scissors	<input type="checkbox"/> Black, butyl rubber <input type="checkbox"/> Insulation tape <input type="checkbox"/> Complete frame

1. Follow the wire pairs from the motors to where they meet inside the tether sheath.
2. Take a small piece (about 2.5 cm) from the black, butyl rubber (soft and ductile like plasticine) and press it around the wire pairs and the tether sheath. Actually, what you do is to insulate the cable pairs, as well as the point where these 3 different

pairs are exposed from the central cable which they come from. Attention! The black, butyl rubber is electrically conductive, thus it shouldn't touch any exposed wires. Once insulating with butyl is over, put insulation tape on top (see Fig. 34).



Figure 34

3. After having sealed the remote control cable, make a loop and tie it on the frame of the vehicle using zip ties. This loop is necessary, because, this way, any tightening of the cable is avoided, when the vehicle is under water.

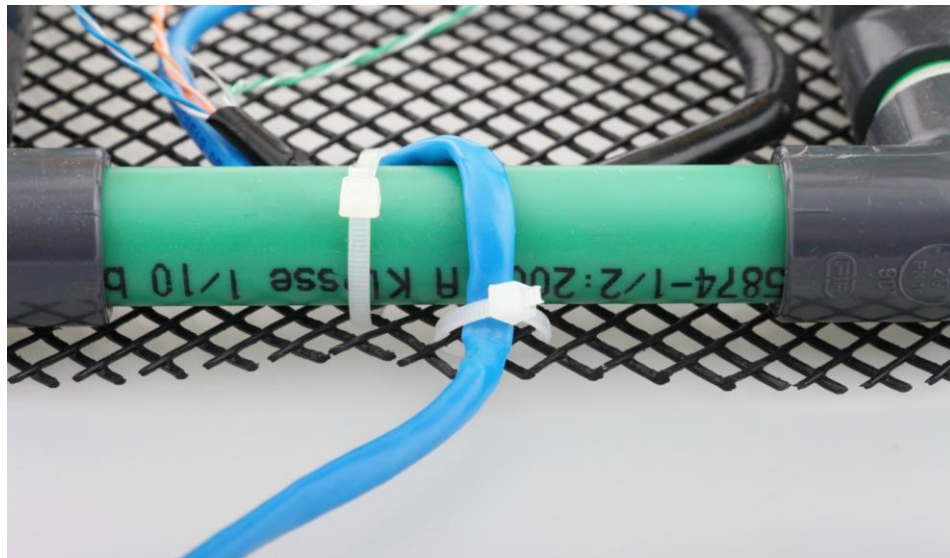

Figure 35

➤ Sub-problem 3: The Remote Control

The following are required for this sub-problem:

Tools	Materials
-------	-----------

<ul style="list-style-type: none"> <li><input type="checkbox"/> Cutter</li> <li><input type="checkbox"/> Screwdriver</li> <li><input type="checkbox"/> Needle-nose pliers</li> <li><input type="checkbox"/> Drill</li> <li><input type="checkbox"/> Soldering iron</li> <li><input type="checkbox"/> 6mm Drill bit</li> <li><input type="checkbox"/> Clamp</li> <li><input type="checkbox"/> Marker pen</li> </ul>	<ul style="list-style-type: none"> <li><input type="checkbox"/> Control box</li> <li><input type="checkbox"/> 2 red switches</li> <li><input type="checkbox"/> 2 black switches</li> <li><input type="checkbox"/> 2 alligator clips (one red one and one black one)</li> <li><input type="checkbox"/> Red cable with safety cap</li> <li><input type="checkbox"/> Insulation tape</li> <li><input type="checkbox"/> White battery cable</li> <li><input type="checkbox"/> 1 red cable No 24</li> <li><input type="checkbox"/> 1 black cable No 24</li> <li><input type="checkbox"/> 10A Fuse</li> </ul>
<p><b>Time:</b> This unit takes about 5 hours to be completed:</p> <ul style="list-style-type: none"> <li>✓ 20 minutes to prepare the control box.</li> <li>✓ 20 minutes to prepare the battery cable.</li> <li>✓ 20 minutes to solder the red switches.</li> <li>✓ 20 minutes to solder the black switches.</li> <li>✓ 20 minutes to finish the box.</li> </ul>	

### Electric Diagram of the Remote Control

The diagram of the electric circuit of the vehicle is shown in Fig. 36. This diagram is a technical representation, which shows the various connections. You can consult the diagram during the construction of this unit, to understand in which way and for which reason the vehicle cabling works.

### Step 1 | Gathering the components of the remote control

<b>Materials</b>
<ul style="list-style-type: none"> <li><input type="checkbox"/> Black control box (remote control)</li> <li><input type="checkbox"/> 2 red switches</li> <li><input type="checkbox"/> 2 black switches</li> <li><input type="checkbox"/> 2 alligator clips</li> <li><input type="checkbox"/> Red cable with safety cap</li> <li><input type="checkbox"/> 10A Fuse</li> <li><input type="checkbox"/> White cable</li> <li><input type="checkbox"/> 1 red cable</li> <li><input type="checkbox"/> 1 black cable</li> </ul>

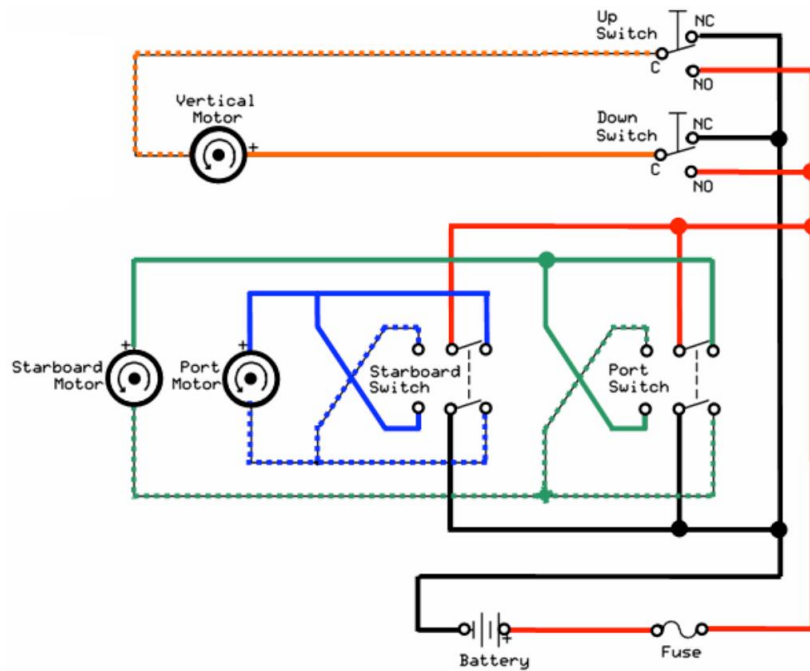

Figure 36

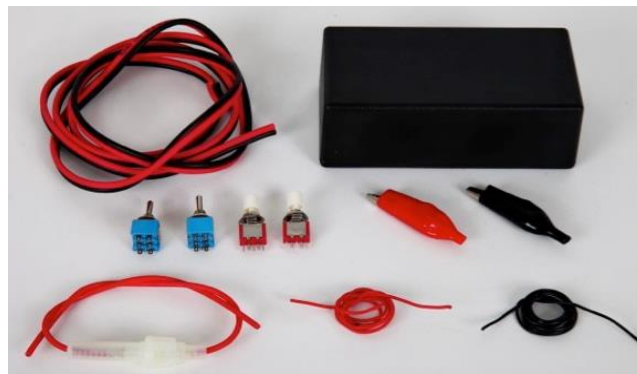

Figure 37

**Note:** Find the test cables (red - black) that are used to check the motors in the previous unit.

### Step 2 | Preparing the control box

Tools	Materials
<input type="checkbox"/> Marker pen <input type="checkbox"/> Drill <input type="checkbox"/> 6mm Drill bit <input type="checkbox"/> Clamp	<input type="checkbox"/> Control box

1. Use the marker to mark the locations of the holes on the control box. The locations of the holes are shown in Fig. 38

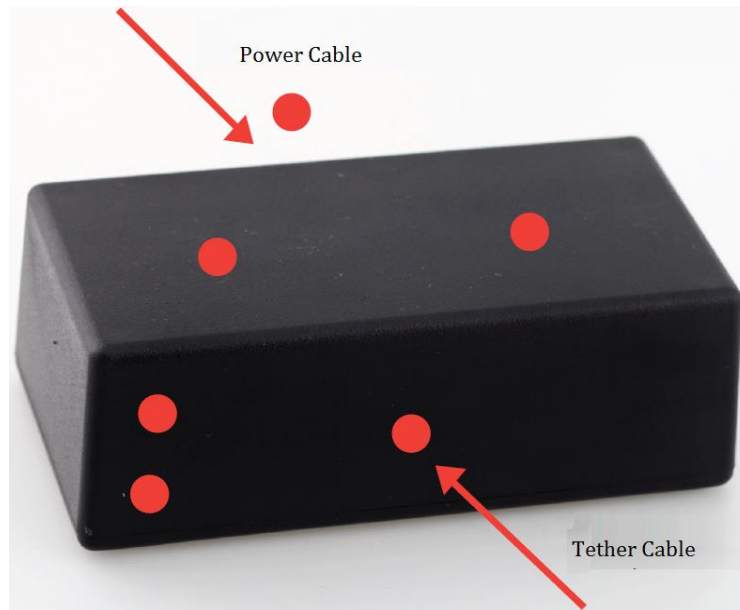

Figure 38

Make sure that the holes are at least at a distance of 1cm from the corners of the box, so that the switches fit into the box. In total, six holes must be drilled, as follows:

- One hole in the centre of the front side of the box, through which the remote control cable will pass (tether cable).
- One hole in the centre of the rear side of the box, through which the battery cable will pass.
- Two holes on the left (according to the figure) part of the front side of the box, through which the switches that control the vertical movement of the vehicle will pass.
- Two holes on the upper side of the box, through which the switches that control the horizontal movement of the vehicle will pass.

2. Mount the box on the clamp and use the drill with the 6 mm drill bit, to drill the holes on the box.

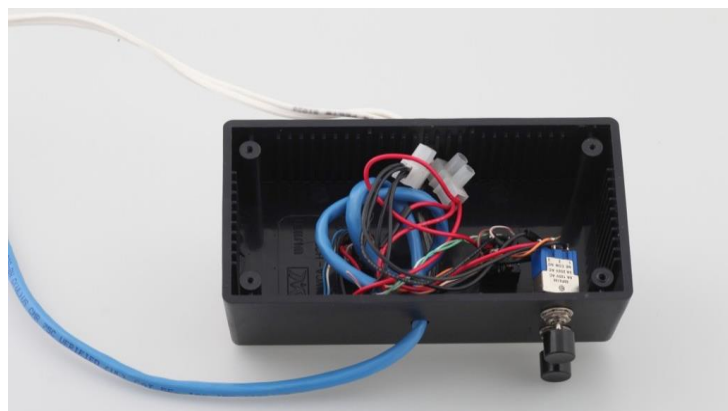

Figure 39

### Step 3 | Assembling the battery cable (power cable)

Tools	Materials
<ul style="list-style-type: none"><li><input type="checkbox"/> Cutter</li><li><input type="checkbox"/> Clamp</li></ul>	<ul style="list-style-type: none"><li><input type="checkbox"/> White cable (speaker's cable)</li><li><input type="checkbox"/> 2 alligator clips</li><li><input type="checkbox"/> Red cable with safety cap</li><li><input type="checkbox"/> Insulation tape</li><li><input type="checkbox"/> Red cable</li><li><input type="checkbox"/> Black cable</li></ul>

1. Cut about 7.5 cm of wire off of the end of the red and black loose wires. Set these short pieces aside for a later use with the toggle switches.
2. Cut the remaining red and black wires into four equal pieces of 12.5 cm.
3. Strip about 6 mm of insulation from each end of each piece. Twist the inner wires (strands) on each end to prevent fraying and breaking.
4. Take the exposed ends of the red cables and “twist” them, so that they are connected, creating a “bunch”. Do the same for the black cables as well. The outcome is shown in Fig. 40.
5. Find the power cable (speaker wire), and determine which side of it is positive and which is negative. Notice that there are two conductors inside, each with its own insulation, and attached to each other with a thin web of insulation material. Usually the insulation on one side is ribbed (like corduroy) and the other is smooth. Other times, one is marked with white or black stripes, or other indicators. We will call the ribbed or marked side the positive (+) side.
6. On each end of the speaker wire (power cord), carefully separate the two conductors for about 2.5 cm. This is best done by snipping the thin web of plastic between the wires with a small pair of scissors, or a fine pair of wire cutters. Be careful not to nick the insulation on the conductors
7. On one end of the power cord, leave the separated section only 2.5 cm long. On the other end, pull the two wires apart for about 35 cm.
8. On the part of the cord that you just separated, find the positive (ribbed or marked) side and cut off 33cm of the positive wire. This section will be replaced with the fuse cap wire, as shown in Fig. 41.





Figure 40

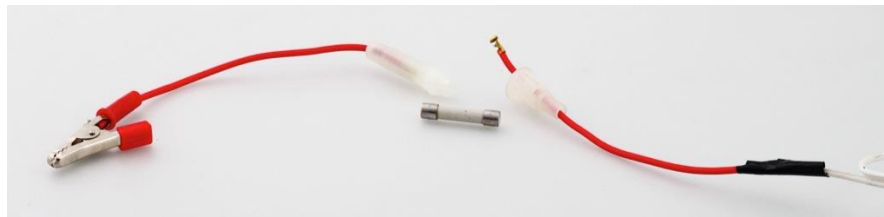

Figure 41

9. Strip 1.3 cm of insulation from both ends of the red cable that includes the fuse.
10. Strip 1/2" (1.3cm) of insulation off of all four ends of the power cord (speaker wire). Twist the conductor strands on each end together to prevent fraying and breaking.
11. Connect the small red cable that includes the fuse to the positive wire of the battery cable (it is the cable from which you removed 33 cm of insulation material). Twist the two wires together and solder them with the soldering iron. Cover them with electrical tape.
12. Connect the red alligator clip to the red cable that includes the fuse. Connect the black alligator clip to the negative side of the power cord. The outcome is shown in the Fig. 42.

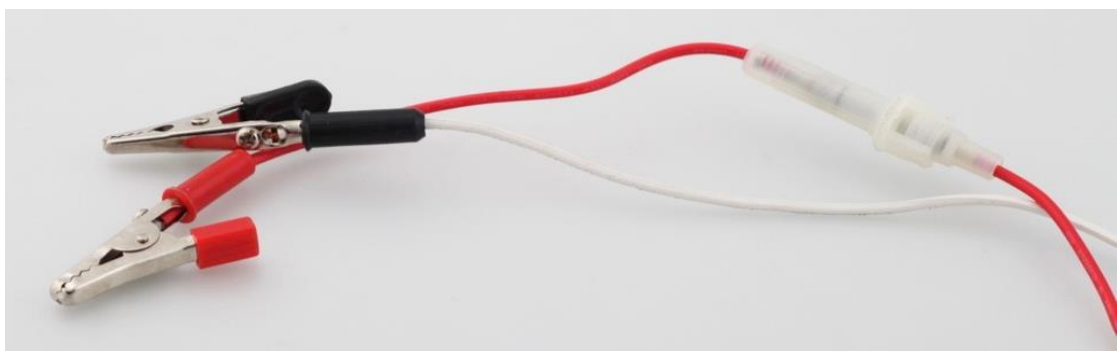

Figure 42

13. Pass the other side of the battery cable (the one with the two separated wires without the alligator clips) through the hole at the rear side of the control box and tie a knot at the bottom of the hole, after you have passed about 15cm of cable through it.

14. Take the positive wire of the white cable. Connect this positive wire to the “bundle” of the 4 small red wires (that you made at the third stage of step 3). Twist them all together. Solder the connections and cover them with electrical tape. Do the same for the other white wire (negative), which you connect to the “bundle” of the 4 small black cables.
15. Remove insulation about 4mm from each one of the 4 red and the 4 black wires.

#### Step 4 | Connecting cables to switches

Materials
<ul style="list-style-type: none"> <li><input type="checkbox"/> 2 red switches (push button)</li> <li><input type="checkbox"/> 2 black switches (lever switch)</li> <li><input type="checkbox"/> Control box</li> <li><input type="checkbox"/> Power cable</li> </ul>



1. Pass about 20 cm from the remote control cable through the hole on the front side of the control box (the front side has 3 holes) and tie a knot at the bottom of the hole to avoid tightening of the cable.
2. Strip about 15 cm of sheath off of the tether cable, being very careful not to nick the insulation on the inner wires.
3. Separate the four twisted pairs. We will be using the orange pair for the vertical thruster, so wrap up the others for now so they are out of the way.
4. Locate the terminal labels above the wire terminals on each switch. “C” stands for common, “NO” stands for normally open, and “NC” stands for normally connected.
5. Wires to solder on Red Switches (push buttons)
  - First switch
    - “C” terminal: the yellow wire from tether cable
    - “NO” terminal: red wire from the bundle
    - “NC” terminal: black wire from the bundle
  - Second switch
    - “C” terminal: the orange wire from tether cable
    - “NO” terminal: red wire from the bundle
    - “NC” terminal: black wire from the bundle
6. Wires soldered to the Black Switches (lever switches)
  - First Switch
    - Upper left terminal: white wire from tether cable plus a small wire which will connect the upper left terminal of the switch with the lower right terminal
    - Upper right terminal: blue wire from tether cable plus a small wire which will connect the upper right terminal with the lower left terminal of the switch

- Middle left terminal: a black wire from the bundle
- Middle right terminal: red wire from the bundle

### Second Switch

- Upper left terminal: black wire from tether cable plus a small wire which will connect the upper left terminal with the lower right terminal of the switch
- Upper right terminal: green wire from tether cable plus a small wire which will connect the upper right terminal with the lower left terminal of the switch
- Middle left terminal: black wire from the bundle
- Middle right terminal: red wire from the bundle

**Attention!** The soldering must be conducted slowly and steadily. Wires must not touch one another, because a short circuit will be caused. Moreover, after soldering is over, you should check if the wires are well soldered by slightly moving them. For an illustration see Fig. 43.

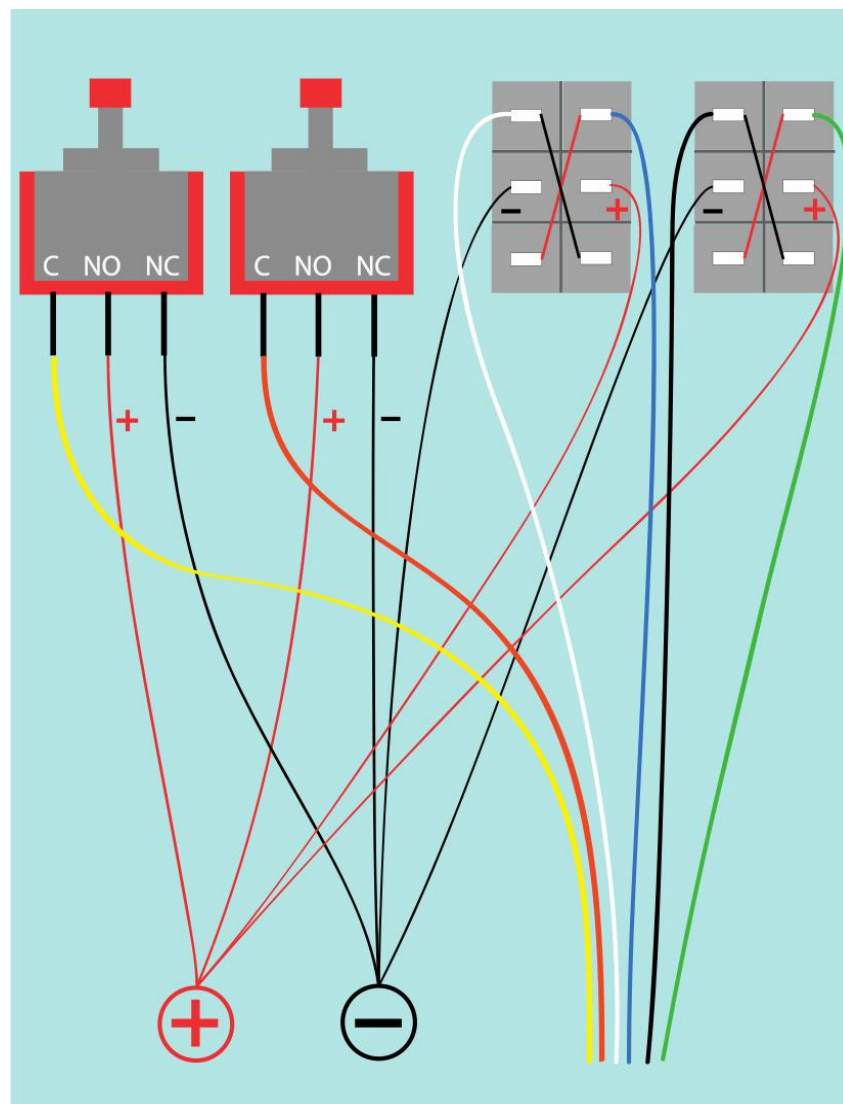
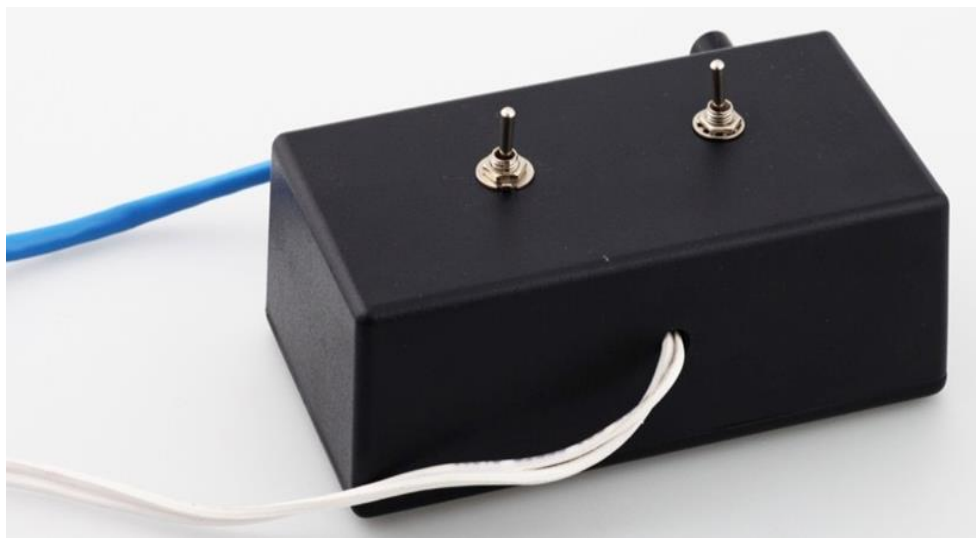

Figure 43

## Step 5 | Completing the remote control

Tools	Materials
<input type="checkbox"/> Screwdriver <input type="checkbox"/> Needle-nose pliers	<input type="checkbox"/> Control box <input type="checkbox"/> Cabled switches

1. Place the lever switches in corresponding holes in the control box. Check the direction that the switches move the motors before securing them into place, (ex. Pressing forward will make the ROV move forward, etc.) Tighten into place with a nut driver or pair of pliers.
2. Remove the red button caps from the button switches by pulling up hard on the red caps. Be careful not to break the white stem.
3. Place button switches through the 2 holes next to the tether cable. Again, check the direction of the switches before securing into place. Tighten with nut driver or pliers. Replace the red button caps by pushing them on very snugly.
4. Screw the back onto the control box using the screwdriver.
5. Place the fuse in the fuse holder.



## Activity 5 – Combine sub-solutions, test and improve

**Duration:** 60 minutes

**Objectives:** In this activity students will

- combine solutions of individual sub-problems to end up with the final design
- test their Hydrobots for buoyancy, control, guidance, speed, and friction.
- familiarize themselves with the control box.

- use their design to probe whether the criteria are met or not
- make all the necessary changes to improve their design
- have fun with their design

### **General Context**

By the end of Activity 4, student teams are supposed to have solved all three sub-problems and have completed the final design. Student teams test their construction in order to confirm that it is functional and meets the criteria set in previous steps.

#### **❖ Working in groups**

The teacher initiates a discussion about the compatibility of the different components of the final design. Student teams are prompted to fit pieces together in order to construct the final artifact. As a last step, the teacher recalls safety issues. As soon as the Hydrobot is completed, student teams move outdoors preferably in a pool area or other water environment like lakes or ports, in order to test their design. Even, if the access to a water resource is not available, a 50 gallon trash can or a small inflatable pool (at least 3 feet deep) is ideal for testing outside from the classroom. Each team performs several tests (every member of a team should try the Hydrobot at least once) of the Hydrobot. The teacher encourages student teams to carefully observe the behavior of the Hydrobot and try to find any flaws or mistakes in their design that if fixed the Hydrobot will be improved substantially.

*-Tip: From an educational standpoint, it's important to allow the children to participate in setting up/cleaning up the room.*

## **Activity 6 – Present Final Solution**

**Duration:** 30 minutes

**Objectives:** In this activity students will

- learn to review and evaluate their work
- present their team work in front of an audience

### **General Context**

The purpose of this activity is to help students realize that they used the same process that engineers use in solving problems. Students also realize that they posed questions and investigated the science that underlies a problem and used already existing technology (tools and materials) in order to imagine, design and construct the final solution to their problem. Student teams, prepare a power point which presents the whole process they followed in order to conclude and construct the final design. Finally they present their work in front of other people.

## ❖ Plenary

The teacher initiates a discussion about how important it is to present your work in front of an audience. It is very important for an engineer to make a clear and comprehensible presentation to an audience who can easily be his/her employer. The teacher should point out that in order to explain something to others you must understand it in depth firstly. Have student teams to prepare a presentation where they explain what they did, how they worked and what the result was. The teacher motivates the audience to put forward questions:

- Did you find any difficulties in applying the Engineering Design Process? What difficulties did you face?
- Was the science knowledge helpful in understanding how to build the Hydrobot?
- Did you change your original design? What affect did this/these change(s) have upon the final design?
- Do the suggested materials work properly and safely? What materials you might substitute?
- What changes did you make to your design in order to improve its performance?
- If you had more time what you would add, change, or do differently?

*If you can't explain it simply, you don't understand it well enough. (Albert Einstein).*

## Science Careers and Your Future

There are numerous scientific, engineering technological elements which are involved in the development of Hydrobots. Some of them are the following:

- **Electrical Engineering:** Electrical engineering is a field of engineering that deals with the study and application of the principles of electricity, electronics, and electromagnetism. The invention of the transistor and the integrated circuit, made electronics cheap enough so that they can be used in almost every household object.
- **Mechanical engineering:** the engineering discipline which applies the principles of engineering, physics and mathematics for designing analyzing manufacturing and maintaining mechanical systems. Mechanical engineers create machines used in manufacturing, mechanical components of electronics, engines and power-generating equipment, vehicles and their components, artificial components for the human body, and many other products.
- **Ocean (Marine) engineering:** the branch of engineering study that deals with the design and operations of manmade systems in the ocean and other marine environments. Ocean engineering includes the engineering of boats, ships, oil rigs and any other marine vessel or structure. Ocean engineers apply their

engineering (mechanical, electrical, electronic engineering) and scientific knowledge in order to design and develop systems and structures in marine environments. An ideal ocean engineer has to achieve a proper tandem between the marine eco-system and the developed human world.

- **Computer engineering:** the discipline that integrates electrical and electronic engineering and computer science in order to design and develop hardware, software, computer systems and other technological devices. Computer engineers embed computers in other machines and systems, build networks to transfer data and develop ways to make computers faster and smaller. Furthermore, computer engineers have expertise in a variety of areas such as software design and coding and are trained to design software and perform and integrate that software with hardware components.

## For Events (tips on setting up and running the challenge in an event setting)

If this challenge takes place in a science festival or a science museum as a:

### i) Mini-Workshop (90 minutes)

As this is a workshop taking place in a festival or in a museum time is relatively limited.

- Skip the Preparatory Activity Strong Paper Table. Discuss with the participants the concepts of engineering and technology. Focus on the Engineering Design Process only as it consists of the core of the whole project.
- From Activity 1 state the problem and focus on the constraints and the criteria that must be met. Have them pose questions concerning the problem.
- Urge the participants to suggest the physical principles that underlie the problem. Skip the experiments proposed in Activity 3 that concern the scientific principles that underlie the engineering problem. Discuss the scientific principles that will be used.
- Review the other activities in terms of content and time, focusing especially on how to respond to questions that might come up.
- To avoid spending time teaching each person how to make a Hydrobot, make samples that illustrate the process.
- Prepare many copies of the instructions as well as enough materials for 4-5 parallel sessions. Establish a testing zone outside from building areas for the testing/ presenting the final designs. A 50 gallon trash can or a small inflatable pool (at least 3 feet deep) may be set up for testing outside.
- Skip Activity 6-Present Final Solution.

## References

- [1]. Build Your Own Underwater Robot and Other Wet Projects, By Harry Bohm and Vickie Jensen, Published by Westcoast Words, Vancouver, B.C., Canada
- [2]. Hewitt, P. G., 2005, Conceptual Physics 10<sup>th</sup> Edition, Addison Wesley
- [3]. Henry Samueli School of Engineering and Applied Science, (2017). What engineers do. UCLA engineering. Available at:  
<http://engineering.ucla.edu/descriptions-of-majors-offered/>
- [4]. College Factual. (2017). Engineering Overview. Available at:  
<http://www.collegefactual.com/majors/engineering/>,  
<http://www.umich.edu/~ptclab/>

